

# Digital Pressure Gauge – DPG8

## Description

DPG8 series digital pressure gauge is made with entire electronic structure, and uses battery as power supply. This gauge is very easy for field installation. DPG8 digital pressure gauge adopts high accuracy piezoresistive pressure sensor, which is located in the front end of DPG8. The output signal of the pressure sensor is processed and amplified by high accuracy and low temperature coefficient amplifier, and then transferred to A/D switch to transform digital signal which can be processed by microprocessor. After processing operation, the pressure gauge will demonstrate the actual value of the pressure by LCD indicator.

The use of DPG8 intelligent pressure gauge is flexible, and its operation is very simple, and the adjustment of this gauge is easy, safe and reliable. DPG8 intelligent pressure gauge is widely used in such industries as water and electricity, running water, petroleum, chemical, and machinery, for the measurement and demonstration of fluid medium's pressure.



## Features

- Double screen, clear and easy to read.
- The screen display 5 digit real-time pressure.
- The second screen can display the maximum, minimum, peak value, ambient temperature.
- Graphical pressure percentage and battery capacity display.
- Exceed pressure alert – to avoid destroying caused by over load pressure.
- White backlight is used for checking at night.
- 10 kinds of selectable engineering units: MPa, kPa, Pa, bar, psi, mmH<sub>2</sub>O, mH<sub>2</sub>O, tor, atm, kgf and NO (NO meaning is no unit selected.)
- Acquisition rate 30sec per time to 100times per sec optional, widely applied.
- Auto power-off will prolong battery life.

## Dimensions 'mm'

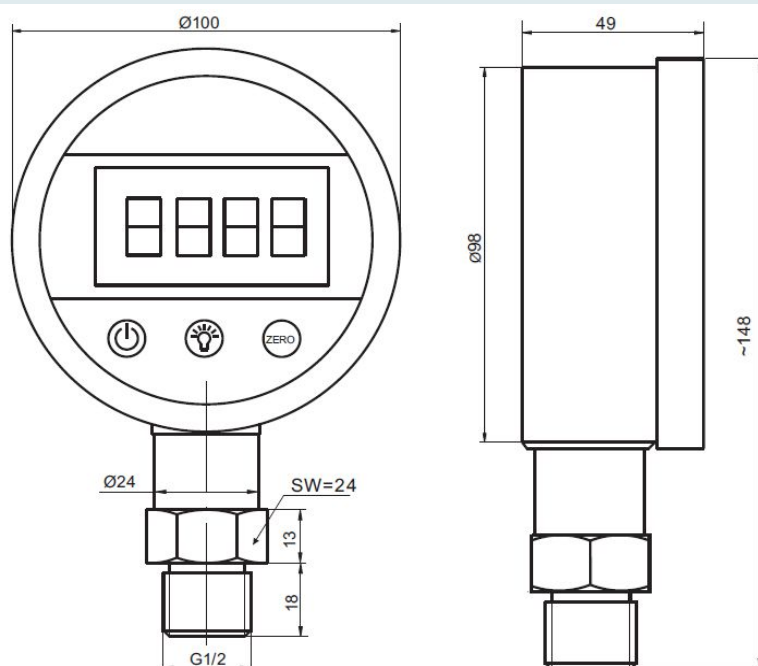

## Specifications

Pressure Medium	Gas or Liquid Compatible to Stainless Steel
Pressure Ranges	-1...0~0.1...1000 Bar
Pressure Type	Gauge (G), Absolute (A), Sealed Gauge (S), Differential (D)
Overload Pressure	150%FS
Accuracy	0.1%FS, 0.25%FS, 0.5%FS
LCD Display	5-Digit
Display Range	-19999 ~ 99999
Long-Term Stability	<0.1%FS/Year
Battery Power Supply	3.6V Battery
Compensated Temperature Range	-30 ~ +70°C
Operating Temperature Range	-30~+100°C
Selectable Ranges	Mpa, kPa, Pa, bar, psi, mmH <sub>2</sub> O, mH <sub>2</sub> O, tor, atm, kgf and NO
Sampling Speed	4 Times/Sec, or Other Options
Insulation Resistance	100MΩ@50VDC
Process Connection	G1/2 or Others
Housing Material	304SS

## Haris Sensor Technologies Private Limited

223, Shanti Industrial Estate, Sarojini Naidu Road, Mulund (West), Mumbai - 400080, INDIA.  
TeleFax: +91-22-2568 3435 / 2567 2204, 2205 ♦ E-mail: info@haris.in ♦ Website: www.harissensor.com

